

# PCO2

## Carbon Dioxide Quality Incident Protection Systems for the sparkling beverage industry - production plant

PCO2 Carbon Dioxide Quality Incident Protection Systems from Parker domnick hunter offer a comprehensive solution to preserve and guarantee the quality of gaseous carbon dioxide used in sparkling beverage bottling.

Using multi-layer adsorbant technology, the PCO2 range includes Maxi PCO2 and Mplus PCO2 for plant scale protection.

Operating as a Quality Incident Protection removing a wide range of potential carbon dioxide impurities, the system guarantees the gas quality so it remains within industry and company guidelines, preventing detrimental consequences to the finished end beverage, producers reputation and their bottom-line.

PCO2 is the beverage industry preferred choice and is installed in over 150 countries worldwide.

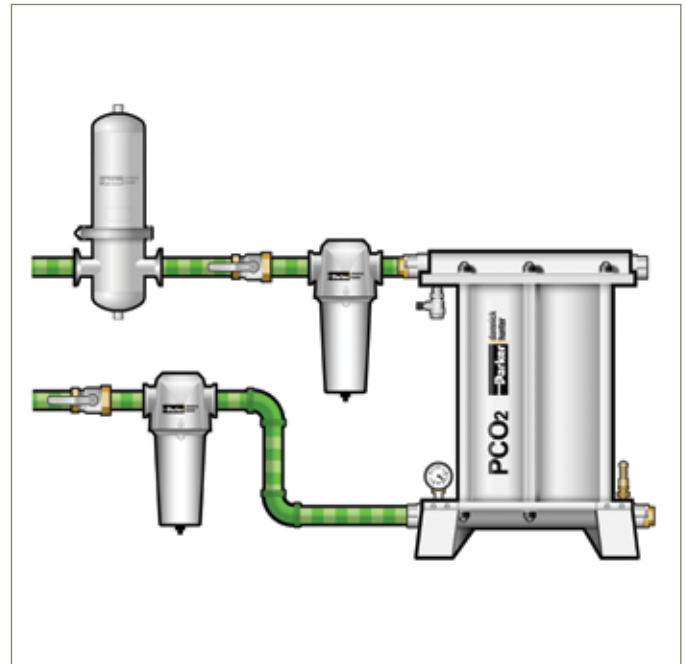

### Contact Information:

**Parker Hannifin Manufacturing Limited**  
domnick hunter Filtration and Separation Division  
Dukesway, Team Valley Trading Estate  
Gateshead, Tyne and Wear  
England NE11 0PZ

**Tel: +44 (0)191 402 9000**  
**Fax: +44 (0)191 482 6296**  
**Email: [dhindsales@parker.com](mailto:dhindsales@parker.com)**  
**[www.parker.com/dhfn](http://www.parker.com/dhfn)**

### Features:

- **Comprehensive six stage technology**
- **Simple installation**
- **Compact design**
- **Low maintenance**
- **Low pressure drop**
- **Meets ISO9001:2000 standards**
- **Materials of construction independent verifications to comply with FDA Code of Federal Regulations title 21 CFR**

### Benefits:

- **Carbon dioxide quality guaranteed**  
Effective in removing a combination of potential impurities and contaminants
- **Protection against impurities known to create beverage flavour defects**  
Helps avoid product spoilage and protects bottlers reputation
- **Ensures carbon dioxide meets industry and company specifications and guidelines**  
Cleans 'out of specification' gas back within beverage quality guidelines
- **International sales and service support**  
Over 20 years experience. Purecare preventative maintenance option available

## Product Selection

Data is based on 20.7 bar g (300 psi g). For flow rates at other pressures, Stated flow rates are at 20.7 bar g (300 psi g). For flows at other pressures apply the correction factors shown below.

Model	Flow Rate	
	Kg/h	Lb/h
Maxi PCO2 - 0	150	330
Maxi PCO2 - 1	300	661
Maxi PCO2 - 2	600	1322
Maxi PCO2 - 3	900	1980
MPlus PCO2 4000	1814	4000
MPlus PCO2 6000	2722	6000
MPlus PCO2 8000	3629	8000
MPlus PCO2 10000	4537	10000

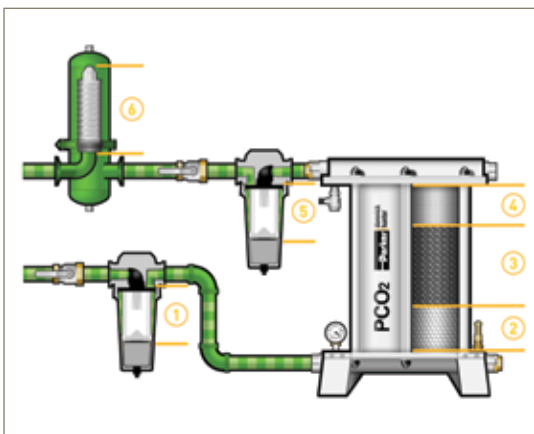

### Stage 1\*

0.01 micron particle filtration  
Removal of non-volatile organic residue (NVOR)  
and other contaminants down to 0.01 ppm

### Stage 2

Removal of water vapour and partial removal of hydrocarbons

### Stage 3

Primary removal of aromatic hydrocarbons  
(Benzene, Toluene etc and Acetaldehyde)

### Stage 4

Removal of sulphur compounds (COS, H<sub>2</sub>S, DMS etc)

### Stage 5\*

0.01 micron particle filtration

### Stage 6\*\*

Point of use VBACE sterile gas membrane. Hi Flow Tetpor II

\* Supplied with every system

\*\* Optional - Sterilizing Grade: consult Parker for operational use

## Technical Data

	Unit	Maxi PCO2	MPlus PCO2
Max. Operating Pressure	bar g psi g	20.7 (24.1 optional) 300 (350 optional)	20.7 (24.1 optional) 300 (350 optional)
Min. Operating Temperature	°C °F	-20 -4	-20 -4
Max. Operating Temperature	°C °F	40 104	40 104
Inlet CO <sub>2</sub> Quality*		ISBT beverage grade CO <sub>2</sub>	

\*PCO2 CO<sub>2</sub> Systems are for gaseous CO<sub>2</sub> only

## Pressure Correction Factors

Inlet Pressure	bar g	3	4	5	6	7	8	9	10	11	12	13
	psi g	44	58	73	87	102	116	130	145	160	174	189
Correction factor		0.19	0.23	0.28	0.33	0.38	0.42	0.47	0.52	0.57	0.61	0.66

Inlet Pressure	bar g	14	15	16	17	18	19	20	21	22	23	24
	psi g	203	218	232	247	261	275	290	304	319	333	348
Correction factor		0.71	0.76	0.80	0.85	0.90	0.95	1	1	1	1	1

## Weights and Dimensions

Model	Systems Connections#	Height (H)		Width (W)		Depth (D)		Clearance*		Weight	
		mm	ins	mm	ins	mm	ins	mm	ins	kg	lbs
Maxi PCO2 - 0	G1	615	24.2	250	9.8	322	12.7	510	20.0	32	70
Maxi PCO2 - 1	G1	621	24.5	250	9.8	464	18.3	510	20.0	48	106
Maxi PCO2 - 2	G1	621	24.5	250	9.8	788	31.0	510	20.0	92	203
Maxi PCO2 - 3	G1	621	24.5	250	9.8	1113	43.8	510	20.0	130	287
MPlus PCO2 4000	G2†	1390	54.7	450	17.7	741	29.2	1155	45.5	270	596
MPlus PCO2 6000	G2†	1390	54.7	450	17.7	910	35.8	1155	45.5	348	768
MPlus PCO2 8000	G2 1/2†	1390	54.7	450	17.7	1079	42.5	1155	45.5	434	955
MPlus PCO2 10000	G3†	1390	54.7	450	17.7	1270	50.0	1155	45.5	518	1140

#Please specify BSP or NPT

†24.1 bar g (350 psi g) versions all 2" connections

\*Clearance required for the removal and servicing of cartridges

For information on extended warranty and preventative maintenance contract availability, please contact your local sales office or visit [www.parker.com/dhfn](http://www.parker.com/dhfn)